

NOVEMBER 2015



DURAFLOOR™
FLOORING SYSTEM



BGC | Fibre Cement

AUSTRALIAN OWNED & MANUFACTURED
WWW.BGCINNOVADESIGN.COM.AU

INTRODUCING INNOVA™

INNOVA™ IS A RANGE OF INTERIOR LINING, EXTERIOR FACADE AND FLOORING PRODUCTS WHICH GIVES A NEW DIMENSION TO THE BGC PRODUCT RANGE. THE PRODUCTS WITHIN THE INNOVA™ RANGE HAVE BEEN DESIGNED TO INSPIRE YOU TO CREATE INNOVATIVE AND DYNAMIC DESIGNS WITHIN YOUR BUILDING OR RENOVATION PROJECT.

DURAFLOOR™ IS THE ULTIMATE FLOORING PRODUCT THAT CAN BE USED IN BOTH INTERIOR AND EXTERIOR APPLICATIONS.

DURAFLOOR™ IS IDEALLY SUITED TO INTERIOR WET AREAS AS WELL AS EXTERIOR PROJECTS.

DURAFLOOR™

- / EASILY INSTALLED USING TRADITIONAL GUN NAILING METHODS
- / REDUCES INSTALLATION COSTS COMPARED TO STANDARD COMPRESSED SHEET
- / USES SAME TONGUE AND GROOVE TECHNOLOGY AS TRADITIONAL SHEET FLOORING SUCH AS STRUCTAFLOOR
- / CAN BE USED IN INTERIOR WET AREAS
 - / BATHROOMS
 - / LAUNDRIES
- / CAN BE USED IN EXTERIOR APPLICATIONS
 - / BALCONIES
 - / VERANDAS
 - / SUN DECKS
- / OR AS A TOTAL FLOOR SOLUTION WHERE A PREMIUM PRODUCT IS REQUIRED
- / HAS GREATER IMPACT RESISTANCE AND FEELS MORE SOLID UNDER FOOT THAN TIMBER-BASED SHEET FLOORING PRODUCTS



CONTENTS

APPLICATIONS	5
ADVANTAGES	5
PRODUCT INFORMATION	5
FIRE RESISTANCE	5
SHEET SIZES AND WEIGHT	5
SHEET PROPERTIES	5
SHEET TOLERANCES	5
HANDLING AND STORAGE	6
CUTTING AND DRILLING	6
HEALTH AND SAFETY	6
FASTENERS	6
INTERIOR INFORMATION	7-14
EXTERIOR INFORMATION	15-22
EXTERIOR FINISHES	22
MEMBRANES	22
MAINTENANCE	22
WARRANTY	22

APPLICATIONS

Durafloor™ is the perfect product to use for interior wet area projects such as bathrooms and laundries but is also ideal for use as the substrate for a variety of exterior decking applications such as above-ground pool surrounds, verandahs and balconies.

ADVANTAGES

- / A single product for interior and exterior projects
- / Tongue and groove system that fits well with particleboard flooring products
- / Easily installed using traditional gun nailing methods reducing installation costs
- / Has greater impact resistance and feels more solid under foot than timber-based sheet flooring products

PRODUCT INFORMATION

Durafloor™ is manufactured from Portland cement, finely ground silica, cellulose fibres and water. After forming it is then cured in a high-pressure steam autoclave to create a durable, dimensionally stable product.

Durafloor™ is immune to permanent damage from water. It is impact resistant, immune to termite attack, non-combustible and easy to work.

Durafloor™ is manufactured to conform to the requirements of AS2908 Cellulose Cement Products, and is classified as Type A Category 3 for external use.

FIRE RESISTANCE

BGC Fibre Cement products have been tested in accordance to Australian Standard AS1530.3.

These tests deemed the following Early Fire Hazard Indices:

- / Ignition Index 0
- / Spread of Flame Index 0
- / Heat Evolved Index 0
- / Smoke Developed Index 0-1

Durafloor™ is deemed to be non-combustible in accordance with BCA section C1.12.

ENERGY EFFICIENCY CONSIDERATIONS

Energy efficiency requirements have been introduced into the BCA for both commercial and residential buildings. Thermal heat transfer into and out of the building envelope can affect the running cost of the building and careful consideration of thermal heat transfer needs to be addressed by the architects, engineers and building designers. Thermal bridging through steel framing will diminish the total R-Value; thermal conductance of the wall. Thermal breaks are required for steel framed buildings and should be installed between the lightweight steel CFS stud and/or top hat sections and the Durafloor™.

Thermal breaks should have a minimum R-Value of 0.2 or less.

QUALITY SYSTEMS

BGC Fibre Cement manufactures Durafloor™ under the rigorous Quality Management System of the International Standard ISO 9001, and is the holder of Licence Agreement number QEC2955/13.

SHEET SIZES AND WEIGHT

NOMINAL THICKNESS mm	WEIGHT kg/m ²	WIDTH mm	LENGTH mm
			2250
19	26.2	600	✓

Weight is based on Equilibrium Moisture Content.

SHEET PROPERTIES

DENSITY	1300kg/m ³
FREEZE-THAW TEST	Passed
WARM WATER TEST	Passed
SOAK AND DRY TEST	Passed
WATER PERMEABILITY	Passed
BENDING STRENGTH	Greater than 7MPa at Saturated condition

SHEET TOLERANCES

Durafloor™ complies with the requirements of AS2908.2

HANDLING AND STORAGE

Durafloor™ must be stacked flat, up off the ground and supported on equally spaced level bearers at 450mm centres.

Durafloor™ must be kept dry, preferably by being stored inside a building. When stored outdoors it must be protected from the weather.

Care should be taken to avoid damage to the ends, edges and surfaces.

Durafloor™ must be dry prior to fixing, jointing or finishing.

CUTTING & DRILLING

Durafloor™ can be cut to size on site. Either Tungsten Carbide or Diamond tipped tools are generally required.

For straight cuts BGC recommends the use of a BGC Durablade fitted to a 185mm circular saw, with a full dust extraction system.



HEALTH & SAFETY

Durafloor™ sheeting is manufactured from cellulose fibre, finely ground sand, Portland cement and additives. As manufactured the product will not release airborne dust, but during drilling, cutting and sanding operations cellulose fibres, silica and calcium silicate dust may be released.

Breathing in fine silica dust is hazardous, prolonged exposure (usually over several years) may cause bronchitis, silicosis or cancer.

AVOID INHALING DUST

When cutting sheets, work in a well-ventilated area and use the methods recommended in this literature to minimise dust generation.

If using power tools for cutting drilling or sanding they must be fitted with appropriate dust collection devices or alternatively use an approved (P1 or P2) dust mask and wear safety glasses.

These precautions are not necessary when stacking, unloading or handling fibre cement products.

For further information or a Material Safety Data Sheet contact the nearest BGC Sales Office.

HOLES

For small holes a well-sharpened Tungsten Carbide masonry drill is recommended. Use a slow drill speed.

Do not use the drills hammer function.

For larger circular holes such as waste holes a Tungsten Carbide or diamond tipped hole saw is recommended.

Alternatively drill a series of small holes around the perimeter of the cut out, and then gently tap out the waste piece while supporting the underside of the opening to avoid damage. Clean up any rough edges with a rasp.

FASTENERS

DURAFLOOR™ TO TIMBER FRAME

Powers Muro M1063 - 10g x 50



Paslode HDG Coil Nail 45 x 2.5



All fasteners to be corrosion resistant- Class 3 minimum.

DURAFLOOR™ TO STEEL FRAME

Buildex Wingtek Screw 10g x 16 x 40



Powers Muro M1024 CSK Screw - 8g x 42



Or similar

WET AREA TILED FLOORS

Durafloor™ is ideally suited as a substrate for ceramic tiled floors in the wet areas such as bathrooms and laundries.

GENERAL

All waterproofing of internal wet areas must be carried out strictly in accordance with Australian Standards AS 3740-2010.

This manual does not contain all information relevant for waterproofing and is to be used as a guide only. It is the responsibility of the specifier to carry out all the necessary design and detailing to ensure the waterproofing and finish satisfy all relevant codes, regulations and system waterproofing manufacturer recommendations.

FRAMING

Durafloor™ sheeting can be fixed to either timber or lightweight steel framing.

Timber framing must comply with AS 1684 “Residential Timber Frame Construction”. Unseasoned timber must not be used.

Metal framing must comply with AS3623 “Domestic Metal Framing”.

BGC recommend sheets to be laid with the long edge across the joists. (Figure 2).

Joist spacing must not exceed 450mm maximum centres.

In all cases a floor joist must support the sheet end.

For all applications the joist face width must be no less than 45mm min.

DURAFLOOR™ NOMINAL THICKNESS (mm)	MAXIMUM JOIST CENTRES (mm)
19	450

LOADING

Durafloor™ satisfies the loading requirements of AS/NZS1170.1 Table 3.1 Category A Domestic and Residential Activities Concentrated Loads 1.8kn @ UDL of 4KPA.

For higher load applications, BGC Compressed Flooring is recommended. Please contact your local BGC Fibre Cement office for further details, or refer to BGC Fibre Cement Compressed Flooring brochure.

FLOOR DRAINAGE

In wet areas lay mortar bed (screed) at a minimum depth of 25mm over the Durafloor™ to produce a minimum 1:60 fall to the waste drain.

Figure 1 depicts a typical floor waste installation showing the waterproof membrane carried down into the fitting. The inner pipe is slotted to allow drainage of the mortar bed (screed).

FLOOR WASTE SKETCH

FIGURE 1
FLOOR WASTE

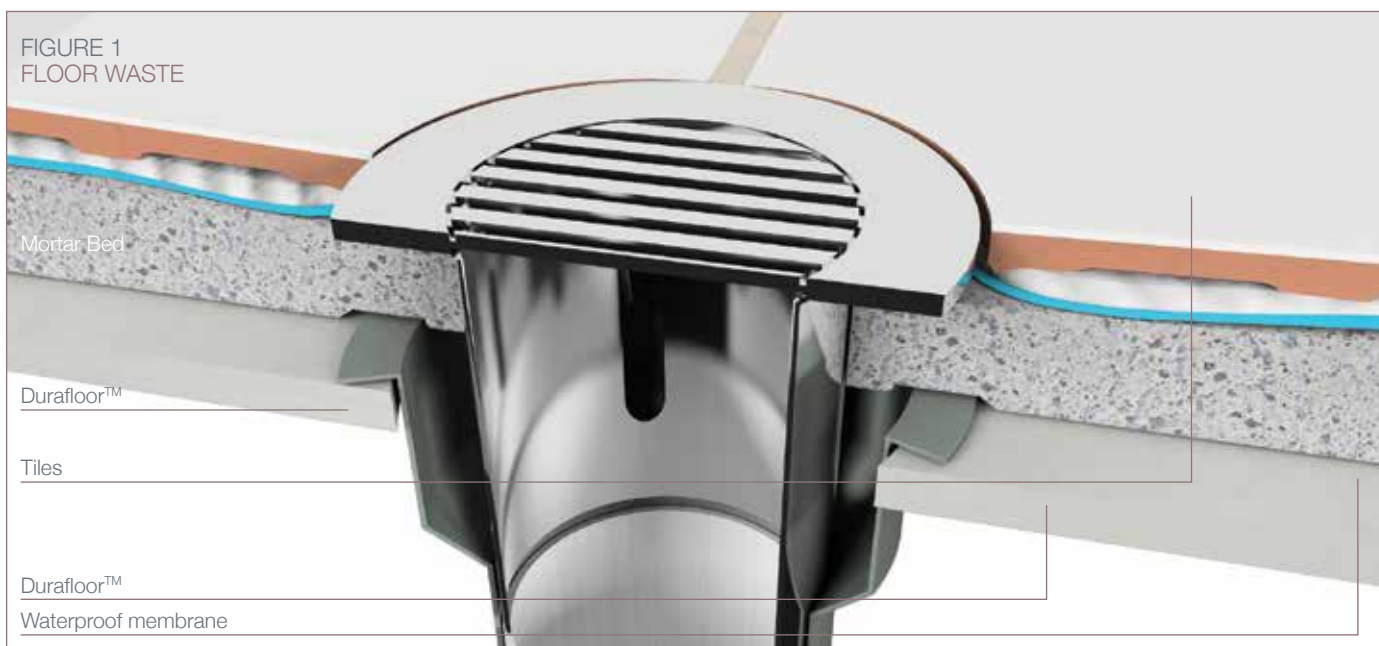

TILED SHOWER BASE RECESS

FIGURE 2
WET AREA

**ENSURE COMPLIANCE WITH
THE BCA AND AS3740-2010**

Notation order follows
installation sequence.

Durafloor™
Duraliner™ Plus
Mortar Bed*
Primer*
Waterproof Membrane*
Tile Adhesive*
Tiles*

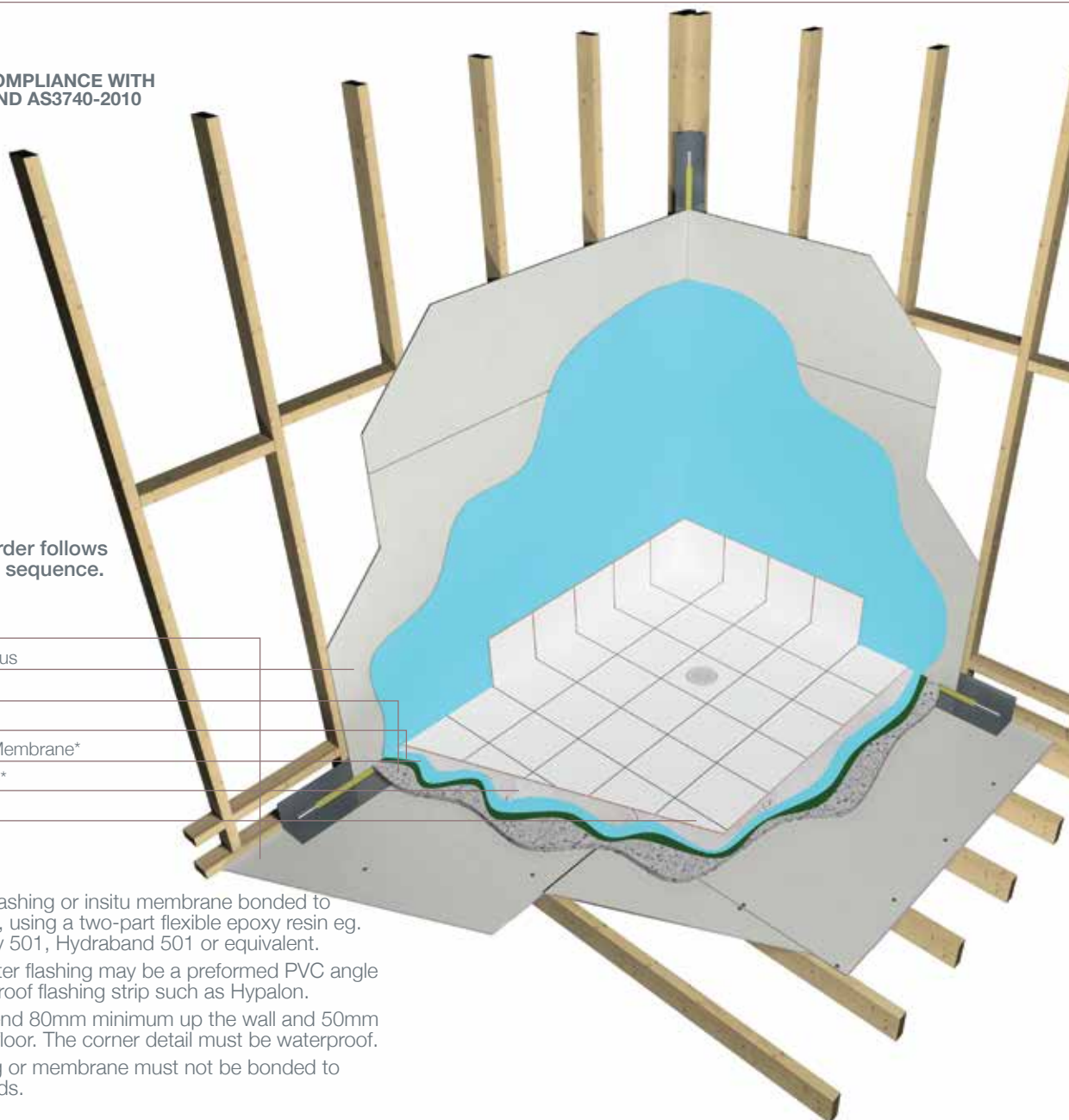

NOTE 2.1

Perimeter flashing or insitu membrane bonded to Durafloor™, using a two-part flexible epoxy resin eg. HydrExpoxy 501, Hydraband 501 or equivalent.

The perimeter flashing may be a preformed PVC angle or a waterproof flashing strip such as Hypalon.

It must extend 80mm minimum up the wall and 50mm across the floor. The corner detail must be waterproof.

The flashing or membrane must not be bonded to the wall studs.

NOTE 2.2

An additional wall nogging must be installed so that the bottom of the Duraliner™ Plus is nailed above the flashing.

NOTE 2.3

The Durafloor™ must be laid across the floor joists as shown.

NOTE 2.4

Lay waterproof membrane over Durafloor™ at a minimum of 150mm upstand of the perimeter flashing.

The membrane must be dressed into the floor waste. (See figure 1).

NOTE 2.5

Lay a mortar bed (screed) over the Durafloor™ to produce a 1:60 fall to the waste drain. See Figure 1.

Ensure all flashings and waterproofing comply with the BCA and AS3740-2010.

Optional regulation - Refer to local Building Authority.

Shower walls are to be water resistant to 1800mm from finished floor level.

*Components not supplied by BGC

PREFORMED SHOWER BASE RECESS

Particular attention is required to the sealing of shower alcoves or recesses.

As with all wet area applications strict adherence to the Building Code of Australia, AS 3740-2010 and local building regulations is essential.

Figures 3 & 4 depict a preformed shower base. Figure 5 depicts a waterproof membrane, which may be either preformed or insitu.

FIGURE 3
SHOWER RECESS

**ENSURE COMPLIANCE WITH
THE BCA AND AS3740-2010**

Durafloor™
Duraliner™ Plus
Mortar Bed*
Primer*
Waterproof Membrane*
Waste

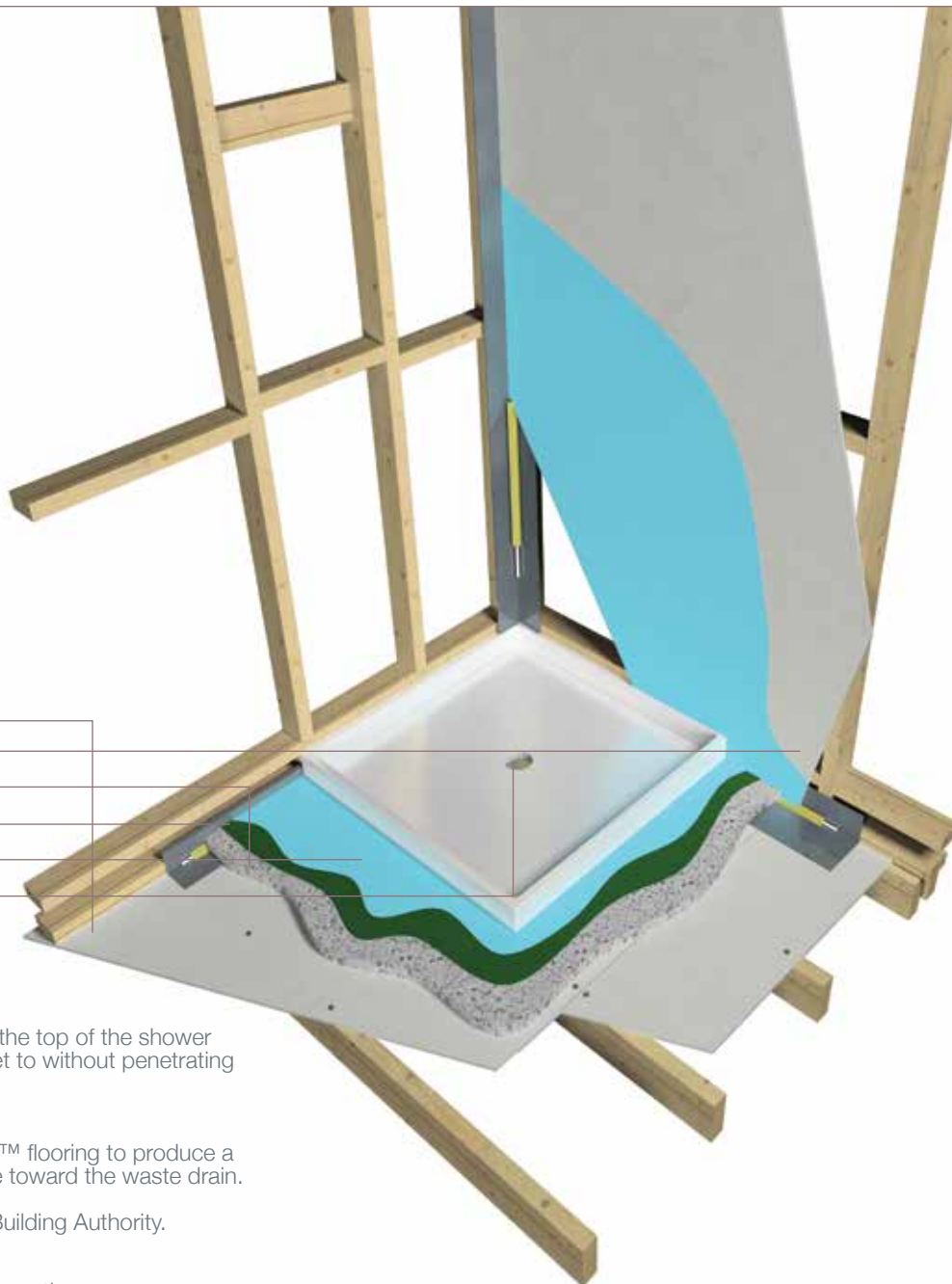

NOTE 3.1

A nogging is required 25mm above the top of the shower tray to nail the Duraliner™ Plus sheet to without penetrating the perimeter flashing.

NOTE 3.2

Lay a mortar bed over the Durafloor™ flooring to produce a 1:60 fall away from the shower base toward the waste drain.

Optional regulation - Refer to local Building Authority.

NOTE 3.3

Durafloor™ sheets are to be laid across the floor joists as shown.

Ensure all flashings and water proofings comply with the BCA and AS3740.

Shower walls are to be water resistant to 1800mm from finished floor level.

*Components not supplied by BGC

SHOWER RECESSES

FIGURE 4
PREFORMED SHOWER BASE DETAIL

**ENSURE COMPLIANCE WITH
THE BCA AND AS3740-2010**

- Durafloor™
- Duraliner™ Plus
- Flashing*
- Perimeter Flashing PEF Rod and Bond Breaker tape
- Primer*
- Waterproof Membrane*
- Shower base*
- Tiles*

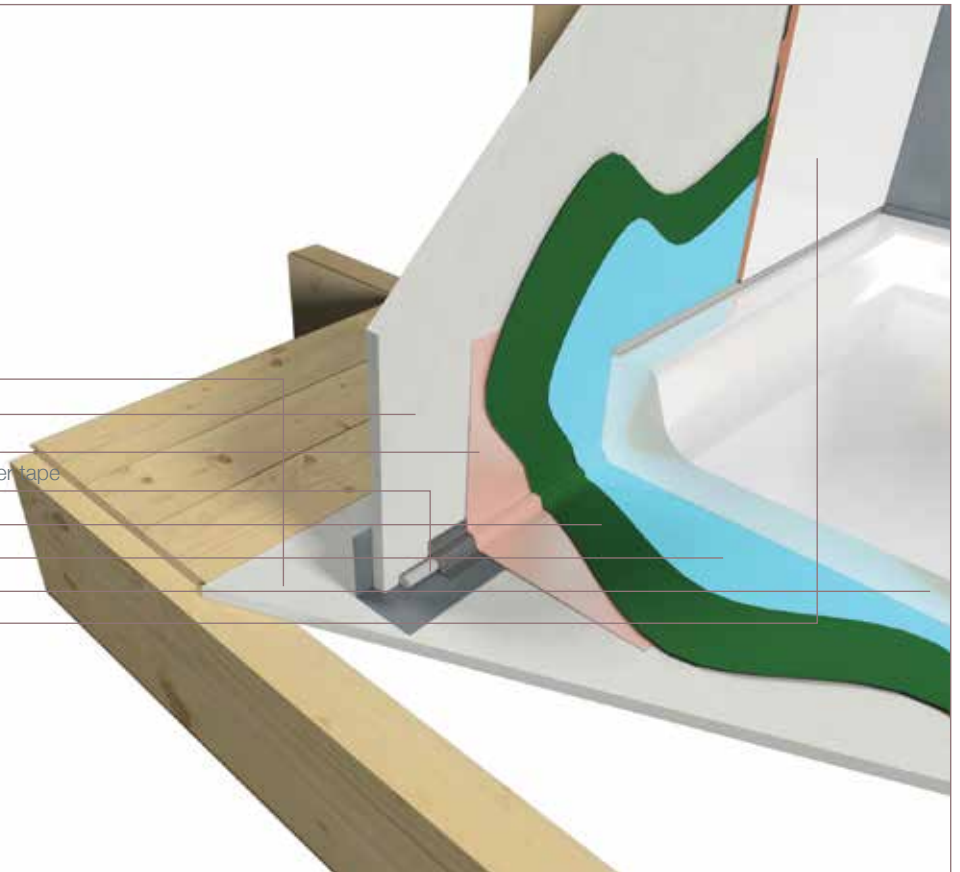
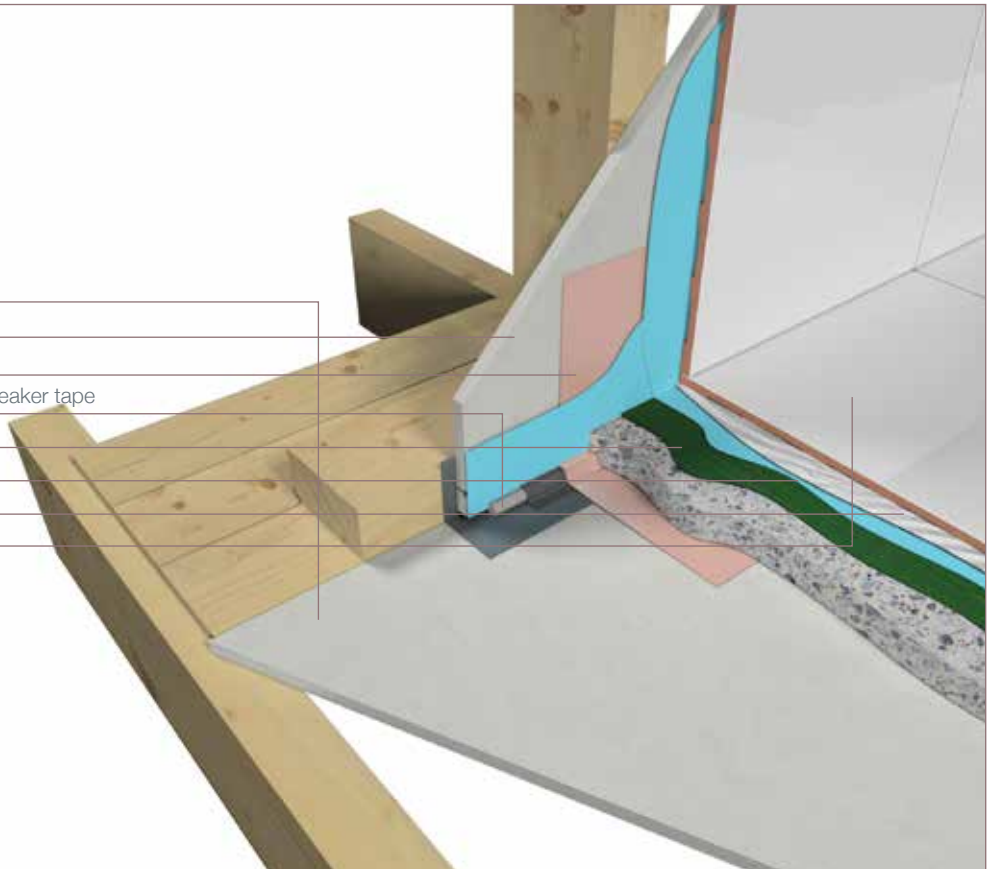

FIGURE 5
USING WATERPROOF MEMBRANE

**ENSURE COMPLIANCE WITH
THE BCA AND AS3740**

- Durafloor™
- Duraliner™ Plus
- Flashing*
- Perimeter Flashing PEF Rod and Bond Breaker tape
- Primer*
- Waterproof Membrane*
- Tile Adhesive*
- Tiles*



*Components not supplied by BGC

INTERIOR TILED FLOORS

In areas where floor waste drains are not required for example kitchens, ceramic floor tiles may be fixed directly to the Durafloor™.

Durafloor™ should be laid across the floor joists using a proprietary tile adhesive conforming to the Australia Standards AS2358 – Adhesives – for fixing ceramic tiles and AS3958.1 – ceramic tiles – Part 1 – Guide to the installation of ceramic tiles.

SHEET LAYOUT

Suitable for wet areas with waterproof membrane fitted and tiled, and non-wet areas fitted with vinyl or carpet.

FIGURE 6
STAGGERED SHEET LAYOUT

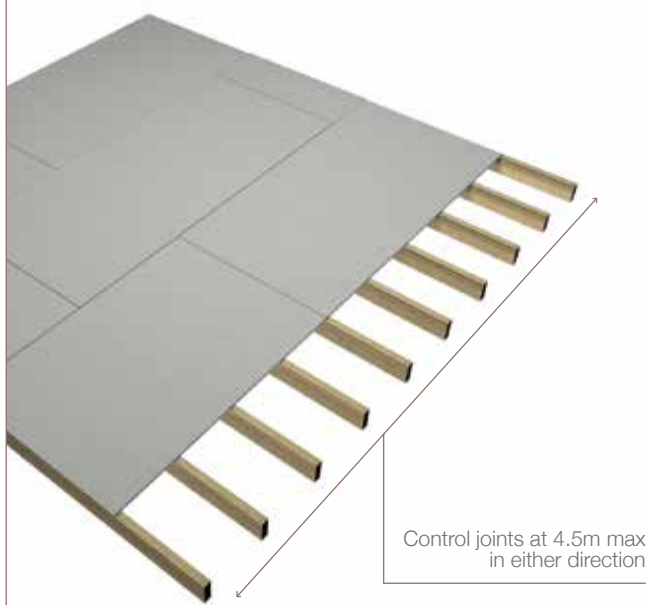

Suitable for non-wet areas tiled.

FIGURE 7
SQUARED SHEET LAYOUT

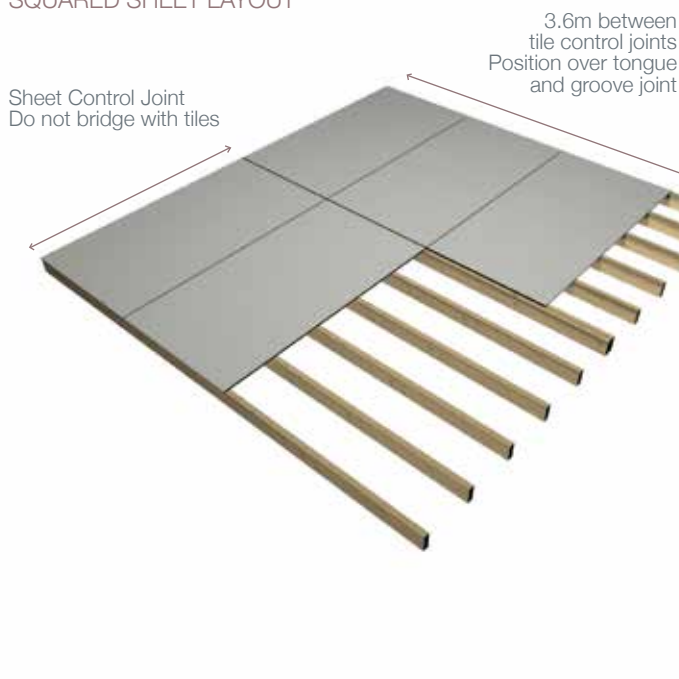

INSTALLATION DETAILS - INTERIOR TILED FLOORS

FIGURE 8
JOIST SPACING

Lay the sheets with long edges across the joists, with the ends of the sheet supported on the centre line of the joist as shown in Figure 9.

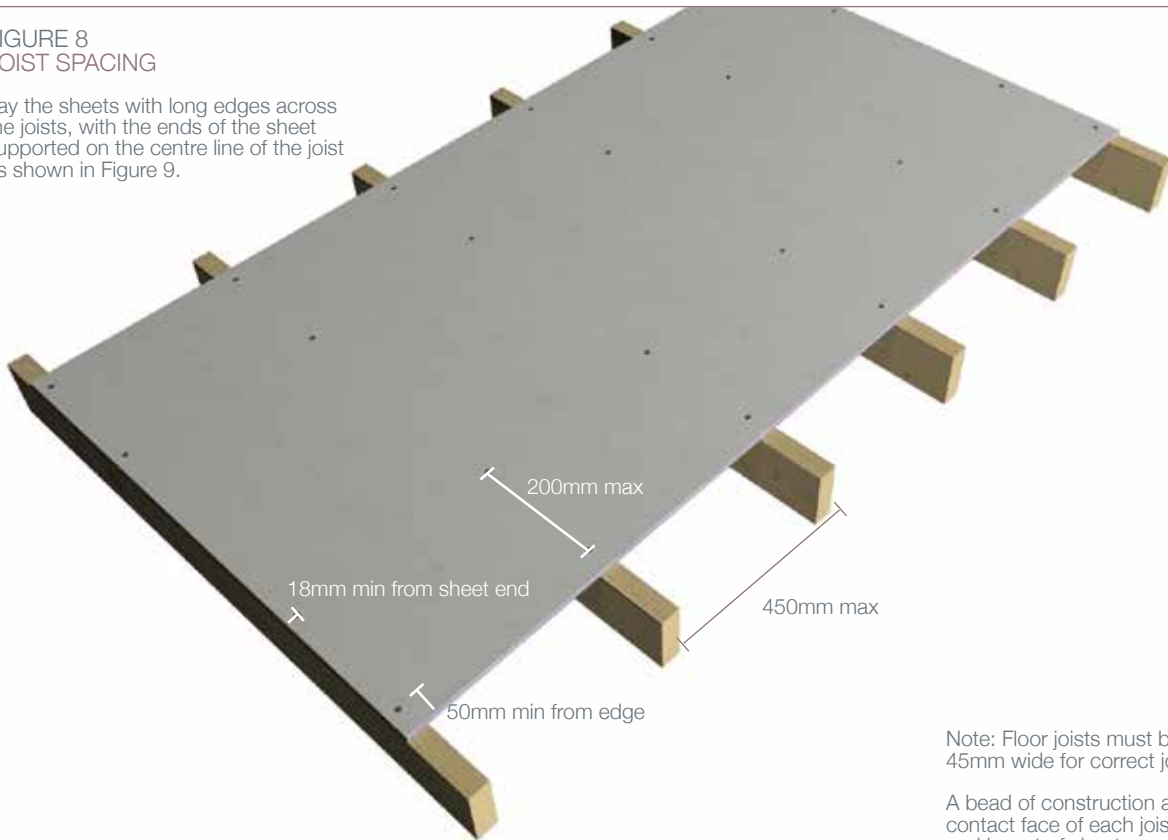

Note: Floor joists must be a minimum of 45mm wide for correct jointing.

A bead of construction adhesive on the contact face of each joist will assist fixing and layout of sheets.

FIGURE 9
BUTT JOIN

Fasteners*

Durafloor™

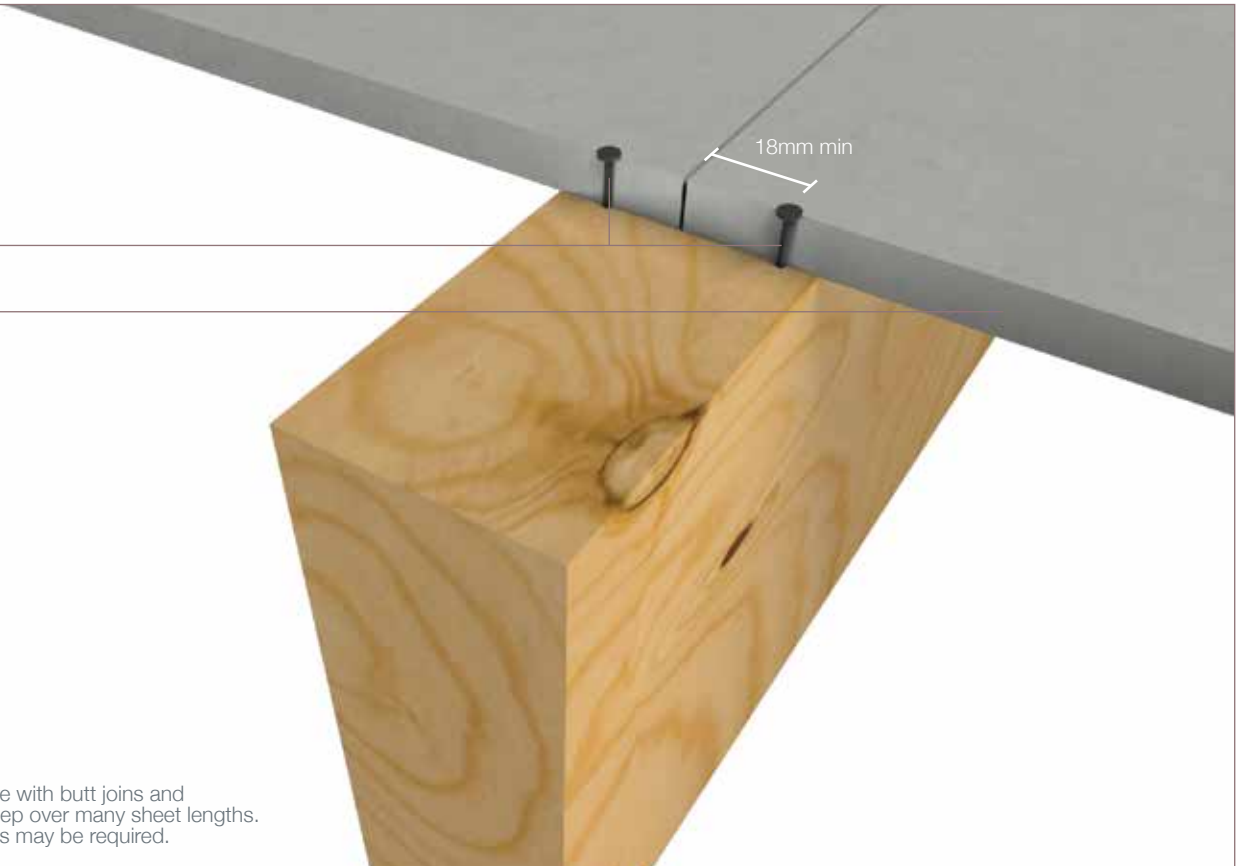

Note: Take care with butt joints and associated creep over many sheet lengths. Additional joists may be required.

*Components not supplied by BGC

INSTALLATION DETAILS - INTERIOR TILED FLOORS

FIGURE 10
WET AREA BUTT
JOIN

Durafloor™
Fasteners*
Backing Rod*
Polyurethane Sealant*



CONTROL JOINT

FIGURE 11
CONTROL JOINT
TILED
NON-WET AREAS

Durafloor™
Fasteners*
Acetic based Sealant*
Primer
Tile Adhesive*
Tiles

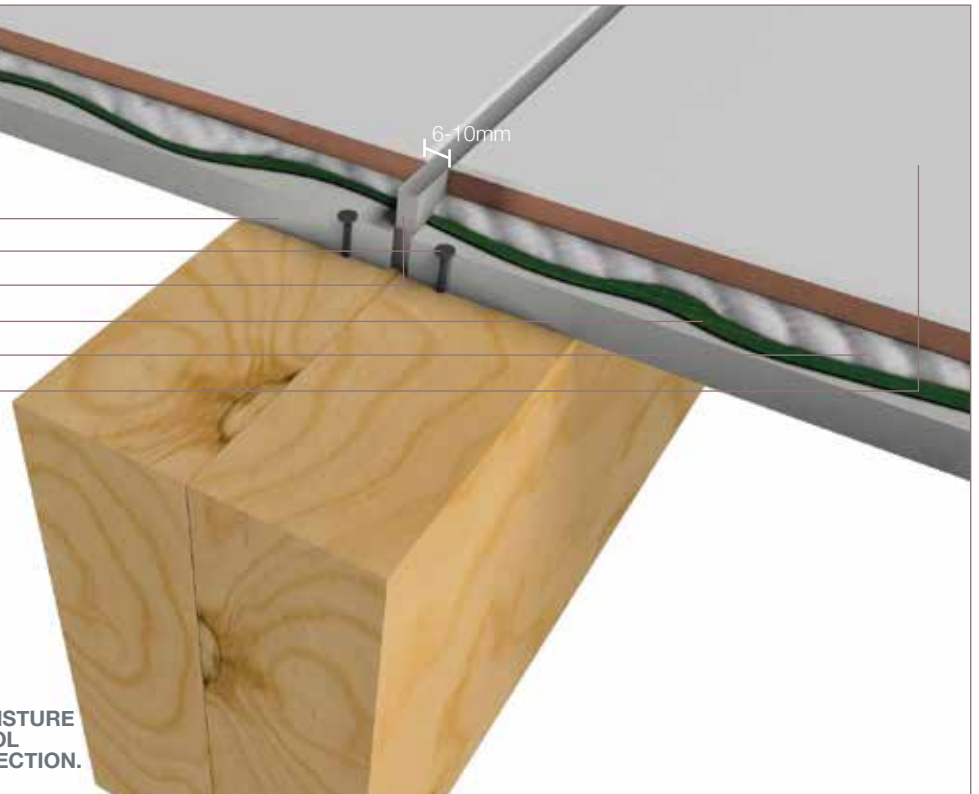

Sheet control joints are required at 3.6m intervals and at a change of direction. This control joint has to be carried through the tiled surface and where existing structural joints are located.

NOTE: TILED AREAS SUBJECT TO MOISTURE AND/OR SUNLIGHT REQUIRE CONTROL JOINTS AT 2.4M TO 3.6M IN EACH DIRECTION.

*Components not supplied by BGC

INSTALLATION DETAILS - INTERIOR TILED FLOORS

FIGURE 12
TILING NON-WET AREAS

Durafloor™

Primer*

Tile Adhesive*

Tiles*

Tile Joint

Tile joint filled with flexible sealant and in line with sheet tongue and groove

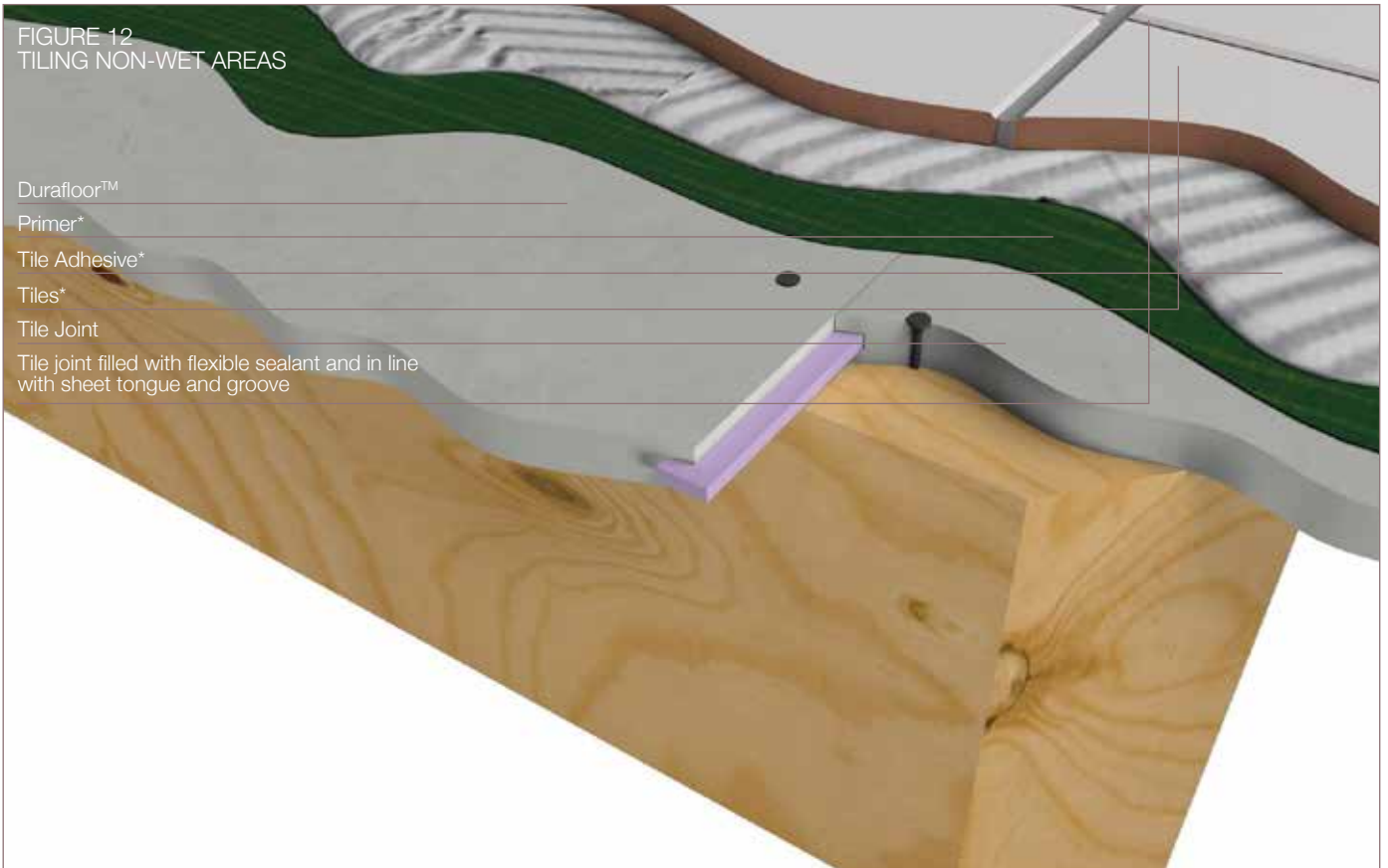

DIRECT STICK TILES TO DURAFLOOR™

Tiles may be adhered directly to Durafloor™ up to maximum run of 4.5m along the length and 4.2m along the width.

It is recommended the Durafloor™ be primed/sealed prior to membranes and to adhesives. Tiling to be installed in accordance with AS3958.1-2007.

*Components not supplied by BGC

EXTERIOR DECKING

Durafloor™ can be used as the substrate for a variety of exterior decking applications such as above-ground pool surrounds, verandahs and sun decks.

The basic requirements of two systems are covered in this brochure.

WATERPROOF WITHOUT MORTAR BED

- / Square sheet layout – refer Fig 20 (max deck width 3600mm)
- / Suitable for tiling (control joints required 2400 – 3600mm in either direction)
- / Applied liquid membrane
- / Not suitable above a habitable room or living space

WATERPROOF WITH MORTAR BED

- / Staggered sheet layout – refer Fig 21
- / Suitable for large decks
- / Suitable for tiling
- / Minimum requirement over a habitable room or living space
- / Achieved via sheet and/or applied membranes plus slipper sheet and floating reinforced mortar bed

GENERAL REQUIREMENTS

All decks shall have a fall minimum 1:100 to an outside edge. The use of sumps in decking is not recommended.

A step down of at least 50mm should be provided at any doorways onto the deck.

If a mortar bed is to be used a minimum depth of 40mm is required.

Sheets are laid with the long edges across the joists. Max joist spacing 450mm centres. In all cases a floor joist must support the sheet ends. The exception being the outer edge of decks where a drip angle is installed.

The gap required for control joints needs to be taken into account when setting out the framing.

Ensure compliance with BCA and all relevant standards.

LOADING

Durafloor™ satisfies the loading requirements of AS/NZS1170.1 Table 3.1 Category A Domestic and Residential Activities Concentrated Loads 1.8kn @ UDL of 4KPA

For higher load applications, BGC Compressed Flooring is recommended. Please contact your local BGC Fibre Cement office for further details.

FRAMING

Timber or hot dipped galvanised steel joists are suitable framing members for Durafloor™.

For all applications the joist face width must be no less than 45mm min.

Control joints will require a double joist to facilitate joint width.

It is **STRONGLY** recommended that joist creep control joint position and double joist positions be considered with sheet layout when setting out.

Timber framing must comply to AS1684 of the BCA and the frame maker's recommendations. All timber must be seasoned and stable. **UNSEASONED OR WET TIMBER MUST NOT BE USED.**

Steel joists must comply with AS3623.

Both steel and timber joists must be suitable for the application and exceed the minimum durability and corrosion requirements.

Responsibility rests with the specifier and controlling party of the project. Suitability of structure and all associated details (as recommended here) for the project is controlled by them. Details contained within this document do not cover all possibilities. It is up to the specifier to develop additional details as required.

WATERPROOFING

Waterproofing a deck is dependant on the membrane and application of that membrane.

Ensure an approved membrane is applied by an approved applicator able to warrant and guarantee the membrane and its application.

Manufacturers like Construction Technologies Australia, RLA Polymers Pty Ltd or Ardex Australia are established manufacturers of these systems.

Ensure compliance with AS/NZ 4654.2.

SHEET LAYOUT - EXTERIOR DECKING

TYPE	SHEET LAYOUT	MEMBRANE
Non-Waterproof	Squared	Required when tile finish used AS/NZ 4654.2 2009
Water Resistant	Squared	Applied liquid membrane to AS/NZ Standard 4654.2 2009
Waterproof	Staggered	Sheet Membrane or Applied Membrane to AS/NZ 4654.2 2009 Slip Sheet floating mortar bed to AS/NZ 4654.2 2009

FIGURE 13
STAGGERED SHEET LAYOUT

Do not direct stick tiles to this layout
To be used with floating mortar bed only

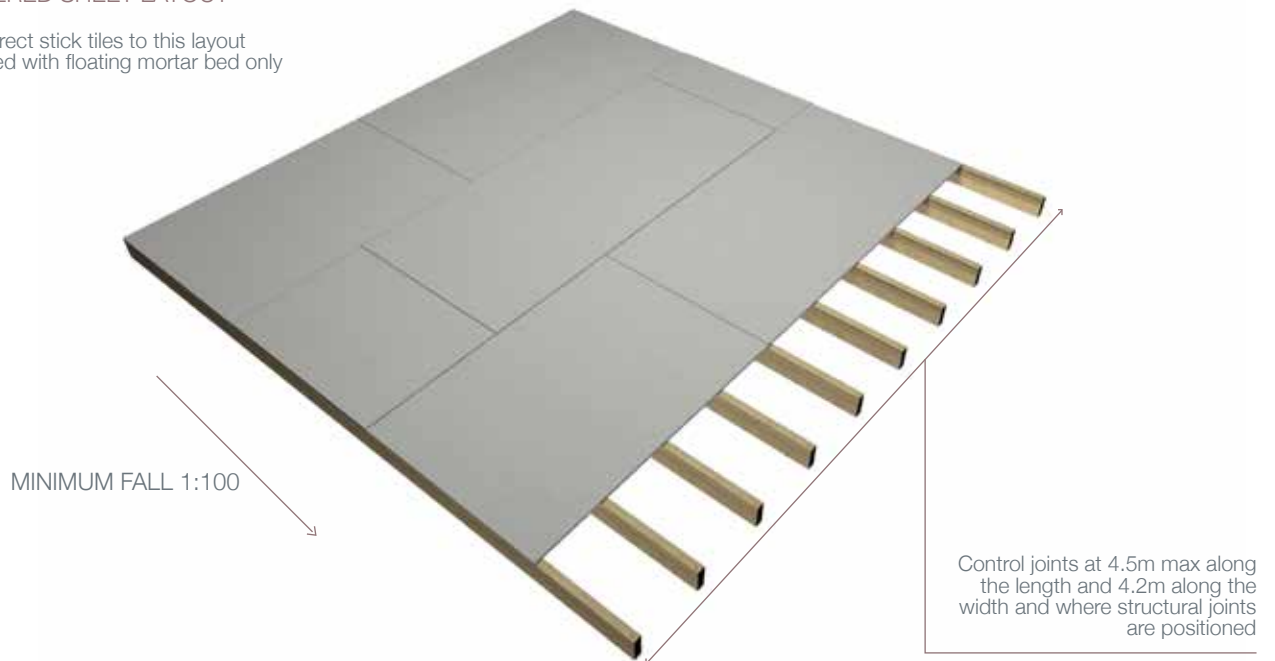

FIGURE 14
SQUARED SHEET LAYOUT

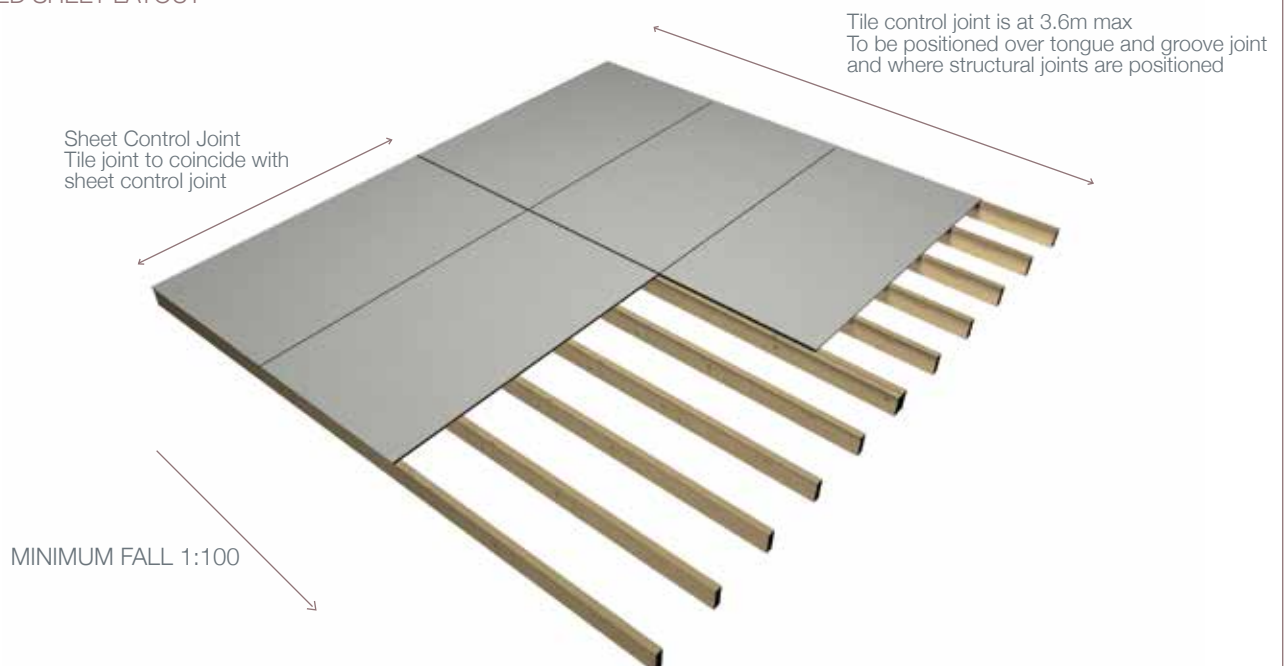
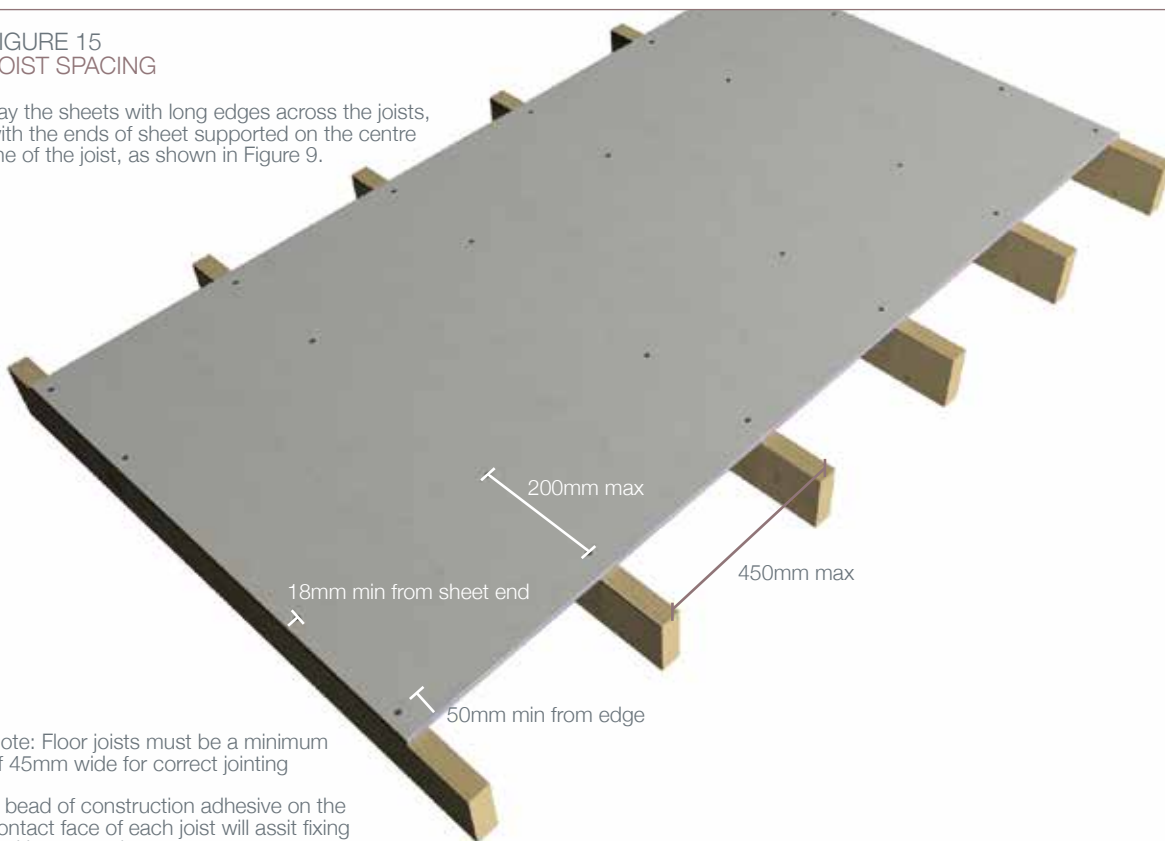

FIGURE 15
JOIST SPACING

Lay the sheets with long edges across the joists, with the ends of sheet supported on the centre line of the joist, as shown in Figure 9.



Note: Floor joists must be a minimum of 45mm wide for correct jointing

A bead of construction adhesive on the contact face of each joist will assist fixing and layout of sheets.

FIGURE 16
CONTROL JOINTS

- Vapour Permeable Sarking*
- Durafloor™
- Backing Rod*
- Polyurethane Sealant*

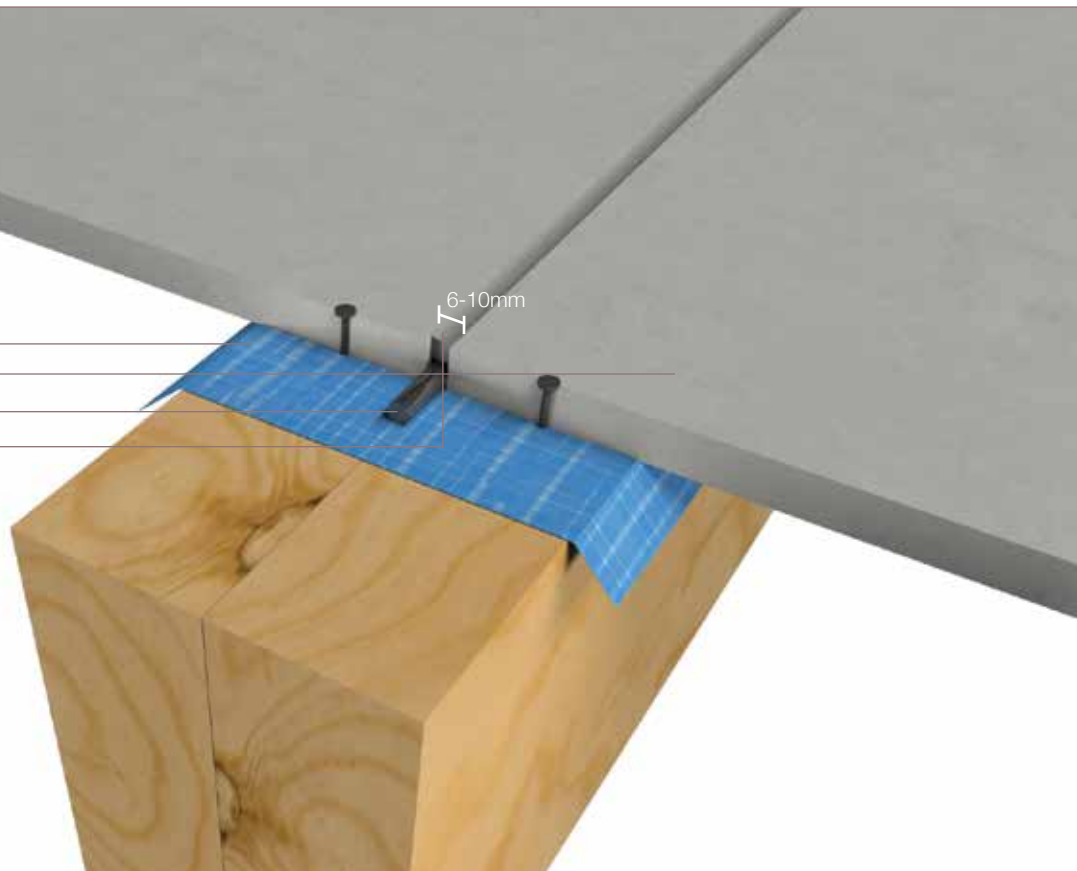

*Components not supplied by BGC

FIXING - EXTERIOR DECKING

FIGURE 17
CONTROL JOINT WITH TILES

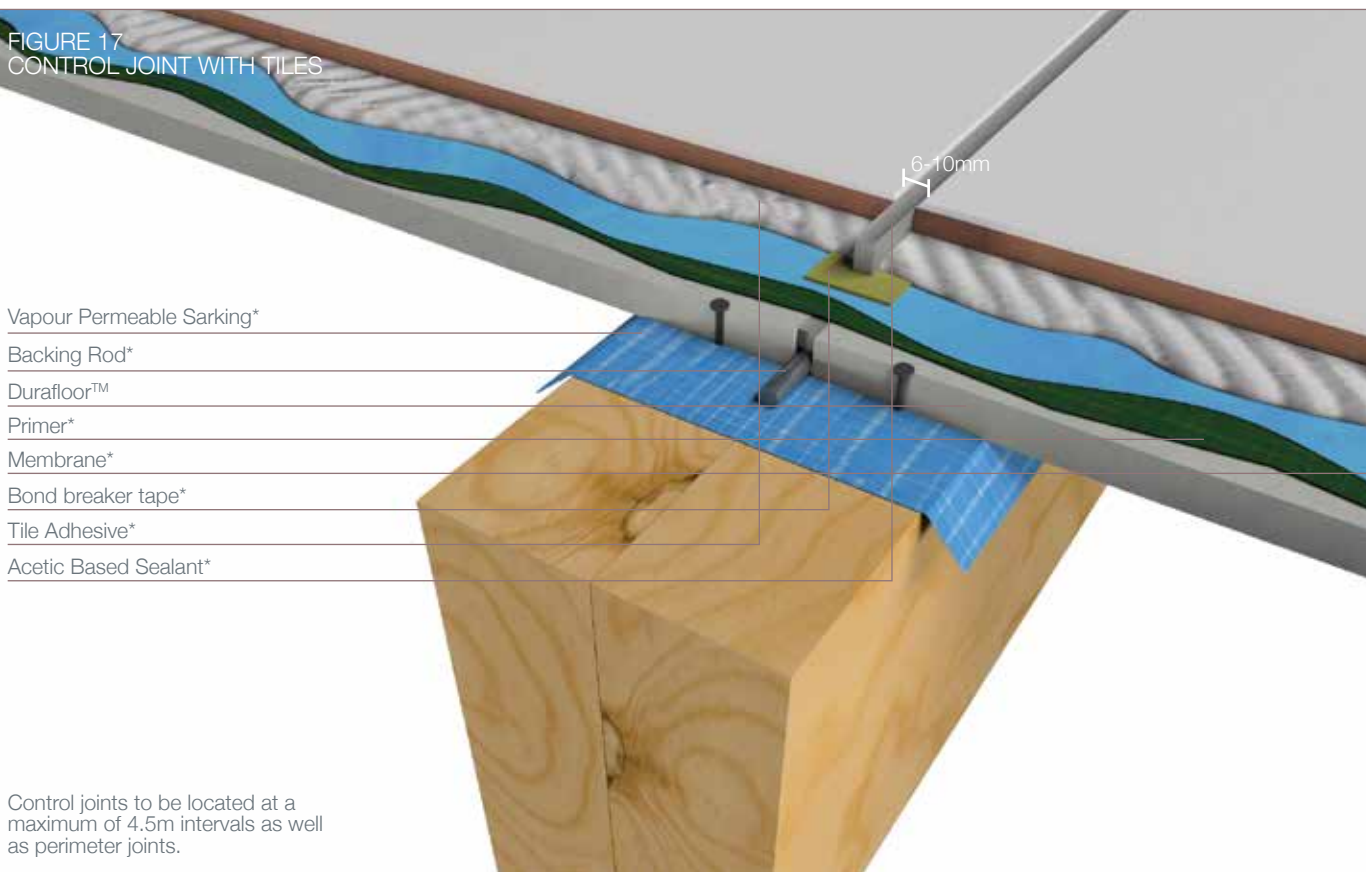

SEALING

After fixing, the screw holes should be sealed using a polyurethane sealant to prevent ingress of water into the framing.

FASTENERS

Durafloor™ can be fixed to either timber or lightweight steel framing. All fasteners to be a minimum Class 3 Corrosion Resistant

Timber: Powers Muro Decking Screw M1062:10g x 50
Paslode HDG Coil Nail 45 x 2.5

Steel: Buildex: SEH Wingtek 10g x 16 x 40 or 10g x 16 x 45
Powers Muro Self Drilling Wing M1024
Or equivalent

*Components not supplied by BGC

DECK FINISHING DETAILS

FIGURE 18
DECK FINISHING WITH TILE FACE

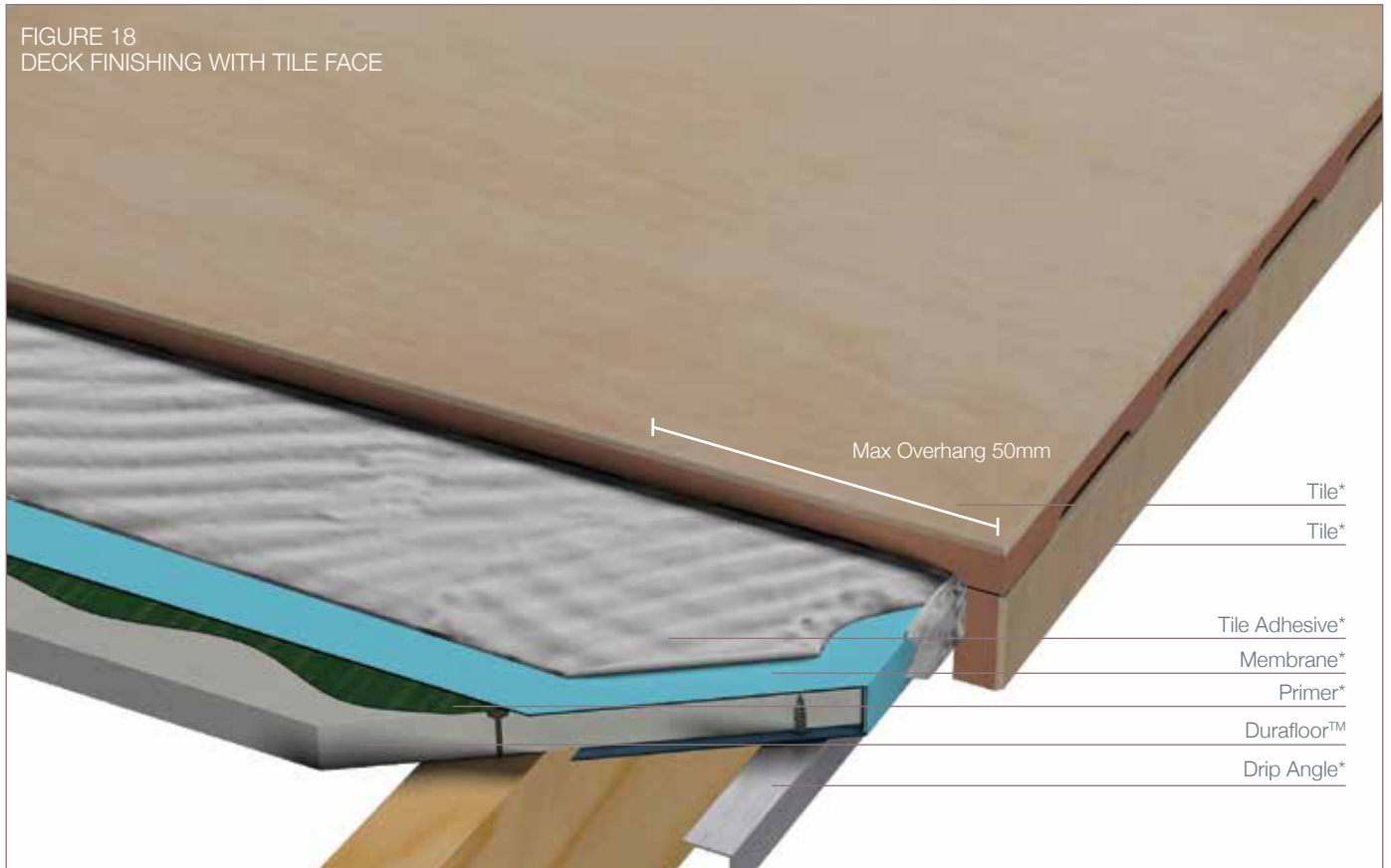
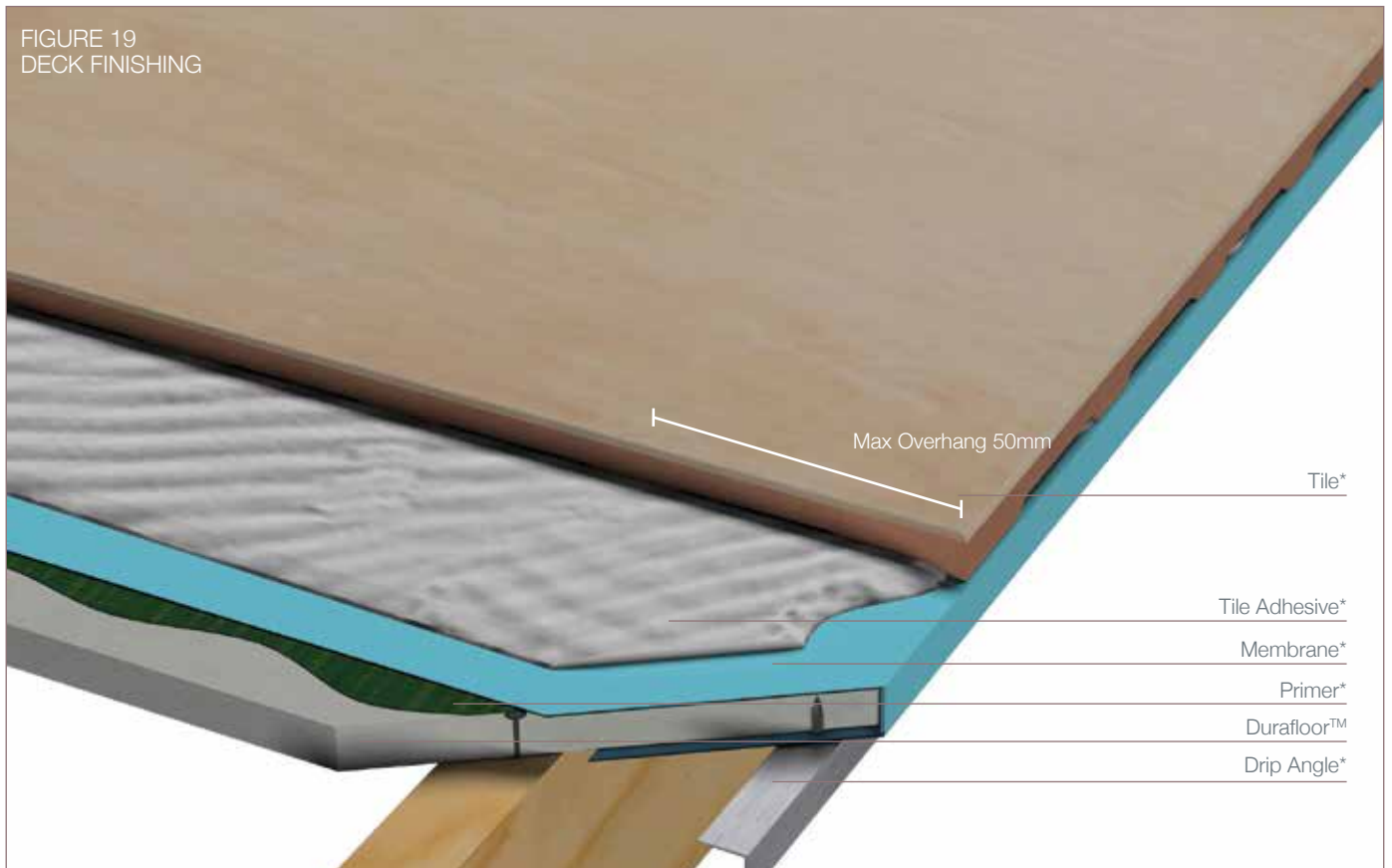

FIGURE 19
DECK FINISHING



*Components not supplied by BGC

EXTERIOR DECK – WATERPROOF WITHOUT MORTAR BED

FIGURE 20
EXTERIOR DECK
WATERPROOF WITHOUT
MORTAR BED

Acetic
Based
Sealant*

Tile control
joint over tongue
and groove
sheet joint

Flashing*

Durafloor™

Primer*

Bond Breaker Tape

Waterproof Membrane*

Tile Adhesive*

Tiles*

Minimum fall of 1:100 is required

SHEET PREPARATION

- / Primer – RLA Polymers – CTA Prep 'n' Prime or Uniflex Additive (Typical) or Ardex Multiprime
- / Membrane – RLA Polymers Dryflex Pump (Typical) Ardex WPM 001/002/ Aquablok SBR / Aquablok 2-part
- / Tile Adhesive – RLA Polymers Flexi Part or Ardex x77, CTA MCB A80 or CTA Pro Premium
- / Tiles – As per manufacturer's recommendations

Tile control joints at 4.5m max in a grid pattern

Refer to Construction Technologies Australia, Ardex and RLA websites for Technical Data Sheets.

*Components not supplied by BGC

EXTERIOR DECK – WATERPROOF WITH MORTAR BED

FIGURE 21
EXTERIOR DECK – WATER PROOF

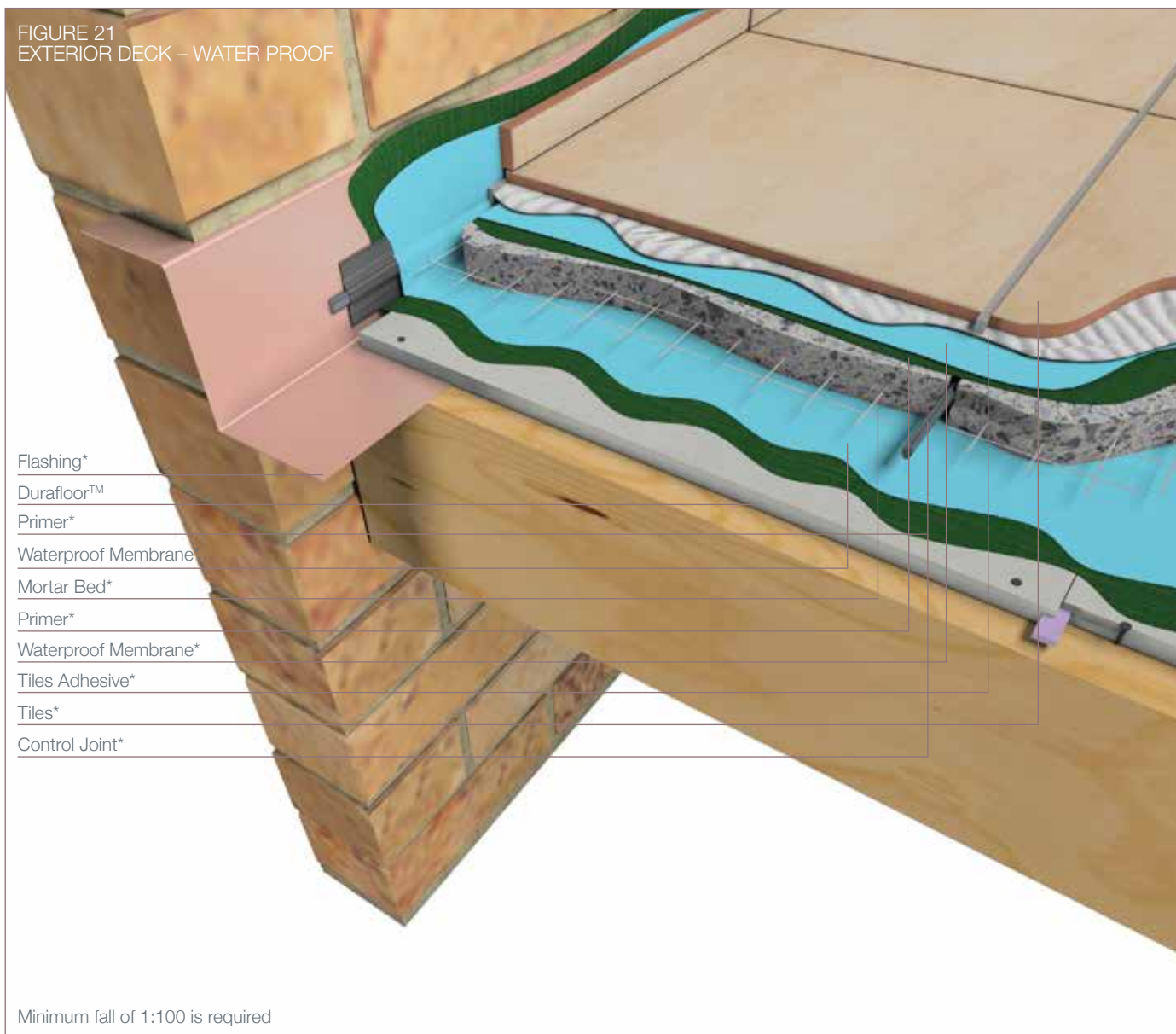

SHEET PREPARATION – FOR TILING

- / Prime sheet – Ardex Multiprime or RLA Polymers– Uniflex Additive / CTA Prep ‘n’ Prime or similar
- / Waterproof Membrane – Ardex WPM001/002 Deck web all joints – RLA Polymers Dryler Pump AquablokSBR / Aquablok 2-part or similar
- / 1 layers of slip sheet i.e. 200 micron plastic builders sheet
- / Reinforced mortar bed minimum 40mm thick as per Australian Standard AS4654 2 (2009). Sand cement screed with Ardex Abacrete (or similar) reinforced with 75 x 75 2.5mm galvanised weld mesh or equivalent
- / Primer – RLA Polymers – CTA Prep ‘n’ Prime or Uniflex Additive or Ardex Multiprime or similar
- / Tile Adhesive – RLA Polymers – Flex Part or Ardex X77 / CTA Pro Premium or MCB A80

Control joints at 4.5m centres in mortar bed. Express control joints through tiles.

Sheet control joints at 4.5m max. intervals in a grid pattern

*Components not supplied by BGC

EXTERIOR DECKS - FINISHES

Tiles – Consult

- / AS3958.1 Part 2 – Guide to Installation of Ceramic Tiles
- / AS2358 – Adhesives for Fixing Ceramic Tiles

OTHER FINISHES – Consult manufacturer for their recommendation and ensure installation complies with the recommendation provided.

MEMBRANES

APPLIED MEMBRANES (EXTERIOR DECKS)

- / Primer – RLA Polymers Uniflex Adhesive as primer or Ardex Multprime or WPM300
- / Membrane – RLA Polymers Dryflex Pump to dry film thickness of 1.0mm or similar
- / Prep 'n' Prime or Ardex WPM 001/002 or similar

In all instances consult with RLA Polymers or Ardex Australia for exact method and specification.

SHEET MEMBRANES

- / Primer – Prime surface with Ardex WPM300 Hydroxy to manufacturer's specifications
- / Membrane – Ardex Butynol in accordance with Ardex technical bulletin TB077. Clean the finish surface as advised

In all instances consult with RLA Polymers or Ardex Australia for exact method and specification.

MAINTENANCE

Maintain the finished surface, keeping the surface clean and free of build up or residue.

Repair and maintain joints, junctions, tiles and grout that are damaged or deteriorated.

Ensure membranes are not prejudiced in any way as damage to these may result in diminished performance and leakage.

WARRANTY

We warrant that our products are free from defects caused by faulty manufacture or materials for a period of 15 years from the date of purchase. If you acquire any defective products, we will repair or replace them, supply equivalent replacement products or refund the purchase price within 30 days of receiving a valid claim subject to product inspection and confirmation of the existence of a defect by BGC. We will bear the cost of any such repair, replacement or refund.

This warranty is given by:

BGC Fibre Cement Pty Ltd
121 Bannister Rd Canning Vale WA 6155
Phone 08 9334 4900 Fax 08 9334 4749

To claim under this warranty, you must provide proof of purchase as a consumer and make a written claim (including any costs of claiming) to us at the address specified above within 30 days after the defect was reasonably apparent, or if the defect was reasonably apparent prior to installation, the claim must be made prior to installation. You may not claim under this warranty for loss or damage caused by:

- faulty or incorrect installation by non-BGC installers (BGC's installation procedures are at www.bgcinnovadesign.com.au);
- failure to comply with the Building Code of Australia or any applicable legislation, regulations approvals and standards;
- products not made or supplied by BGC;
- abnormal use of the product; or
- normal wear and tear.

The benefits available under this warranty are in addition to other rights and remedies of the consumer under the law. Our goods come with guarantees that cannot be excluded under the Australian Consumer Law. You are entitled to a replacement or refund for a major failure and for compensation for any other reasonably foreseeable loss or damage.

You are also entitled to have the goods repaired or replaced if the goods fail to be of acceptable quality and the failure does not amount to a major failure.

CONTACT

TO CONTACT
YOUR NEAREST
BGC STOCKIST,
PLEASE CALL:

ADELAIDE
TELEPHONE
08 8250 4962

BRISBANE
TELEPHONE
07 3271 1711

MELBOURNE
TELEPHONE
03 9392 9444

PERTH
TELEPHONE
08 9334 4900

SYDNEY
TELEPHONE
02 9771 9660

NEW ZEALAND
TELEPHONE
0011 64 9273 1457

TECHNICAL HELP LINE
1300 652 242



Quality
ISO 9001
SAI GLOBAL

BGC FIBRE CEMENT IS A
PROUD AUSTRALIAN OWNED
MANUFACTURER OF FIBRE
CEMENT PRODUCTS.

BGC FIBRE CEMENT PROVIDES
BUILDERS, DEVELOPERS AND
ARCHITECTS WITH A RANGE OF
DESIGN ALTERNATIVES AND
INNOVATIVE PRODUCTS,
SUCH AS:

EXTERIOR PRODUCTS AND APPLICATIONS INNOVA RANGE OF PRODUCTS

DURACOM™ / A compressed fibre cement facade system.

DURAFLOOR™ / Is the ultimate flooring product that can
be used in both interior and exterior applications.

DURAGRID™ RESIDENTIAL & DURAGRID™ LIGHT COMMERCIAL /
A lightweight facade giving a modern and durable finish.

DURAGROOVE™ / A vertically grooved exterior facade panel.

DURASCAPE™ / A lightweight exterior facade base sheet with
a subtle vertical shadow line.

NULINE™ PLUS / A weatherboard style cladding system.

STONESHEET™ / Purpose designed substrate for stone tile facade.

STRATUM™ / Is a range of plank products, each of which can be used
as stand alone products or used together to create a striking exterior
cladding solution.

STRATUM™ ERA / A traditional, yet contemporary as it is
flat weatherboard.

EXTERIOR PRODUCTS AND APPLICATIONS BGC FIBRE CEMENT RANGE OF PRODUCTS

DURASHEET™ / Ideal for the cladding of gables and lining of
eaves. Can also be used on commercial soffits and cladding
on non-impact areas.

DURAPLANK™ / Available in Smooth, Woodgrain and Rusticated
finishes, Duraplank™ is ideal for exterior cladding of upper storey
conversions or ground level extensions.

DURATEX™ / A base sheet used for textured coatings on exterior
wall applications.

DURALINER™ PLUS / An exterior lining board, this is the perfect
substrate for tiles and is ideal for wet areas.

DURALATTICE™ / Square or diamond patterned lattice, suitable for
screens, pergolas and fences.

COMPRESSED / Used for domestic, commercial sheet for wet areas,
flooring, partitions, exterior decking, fascia and facade cladding.

DURALUX™ PLUS / Suitable for exterior applications where it will be
sheltered from direct weather.

INTERIOR PRODUCTS AND APPLICATIONS BGC FIBRE CEMENT RANGE OF PRODUCTS

DURALUX™ PLUS / An interior lining board suitable for
ceilings and soffits.

DURALINER™ PLUS / An interior lining board, this is the perfect
substrate for tiles and is ideal for wet areas.

CERAMIC TILE UNDERLAY / A substrate for ceramic
and slate floor tiles.

VINYL CORK FLOOR COVERINGS /
A substrate for vinyl floors.